

# UR2000-2100

## Constant Current Regulators New Generation

Compliances: FAA AC 150/5345-10G (L-828 & L-829)  
IEC 61822 Ed.2 and IEC 61821 Ed. 2.0  
ICAO Aerodrome Design Manual, Part 5  
ANEXO 20, AENA PPT 002-04/04



### Applications

The single-phase constant current regulators, series UR2000 and UR2100, have been particularly designed to provide power to airport lighting series circuits; particularly these regulators assure sinusoidal current (see THD feature) either at the input or at the output, high power factor, elevated efficiency and low distortion (see THD feature), also in case of very low load.

These constant current regulators are suitable for operation under the following environmental conditions:

- protected ambient;
- temperature comprising between - 40° C and + 55° C, including monitoring circuitry;
- height above sea from 0 up to 2000 m;
- humidity from 10% through 95% (not condensing).

### Features

- **L-828 and L-829 FAA Approved**, ETL Certified.
- **UR2100** regulators are equipped with two independent power modules for maximum reliability: one for normal operation, utilizes PWM controlled power transistors with forced ventilation (Patented Topology), the other, as stand-by, two anti-parallel thyristors with natural cooling. "Zero" commuting time between the two modules.
- **UR2000** regulators are the same as UR2100 without SCR power unit.
- DSP (Digital Signal Processor) control for maximum performance improvement, very large operating data information and user-friendly diagnostic.
- Soft start with adjustable warm-up.
- Operation keyboard for local control.
- Auxiliary keyboard to scroll the display visualization and to access the menu for programming purpose.
- Max 8-step output current, each adjustable between 1.8A (for service purpose only) and 6.6A.
- Integrated input and output lightning arresters (opt. 74 and 5 respectively for IEC version).

### How to order

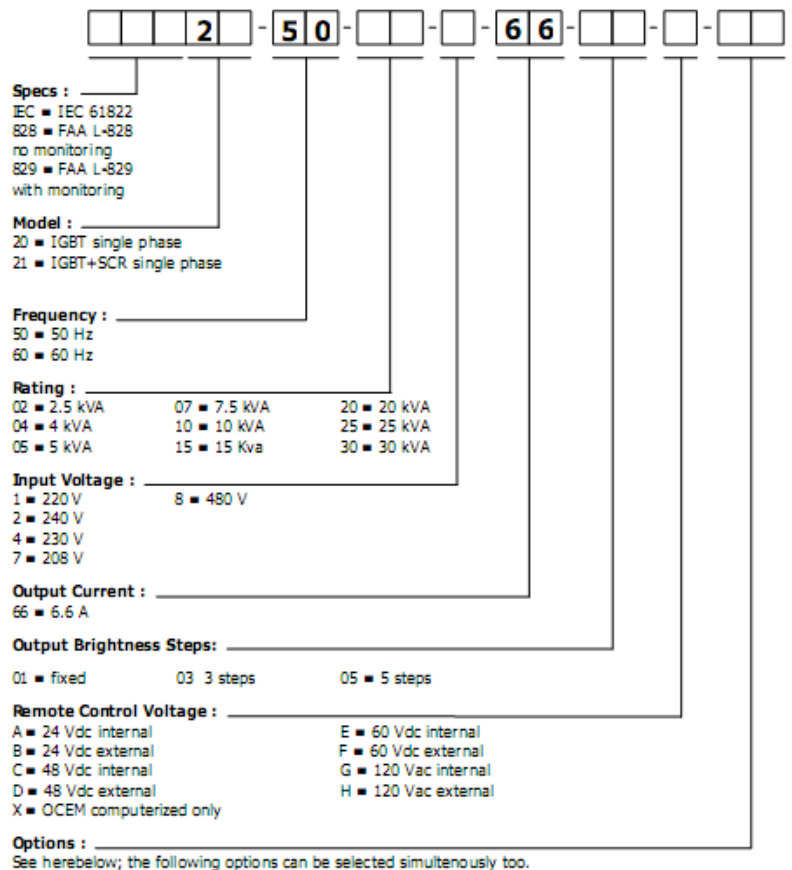

- Alphanumeric LCD display, with four-line twenty characters each, to provide information about the regulator status-operation, to show input-output electrical data, time operation (total and at each step) and any warning-alarm condition, and to allow the calibration activity.
- Large STEP Display (one digit 7-segment multi-colour led display) to provide an immediate information about the CCR status.
- Open circuit protection.
- Overcurrent protection.
- Input power loss, output power drop and output current mismatching detection always available.
- Integrated L-829 monitoring. Optional integrated circuit selector control (up to four ways).
- Integrated parallel wiring remote control interface.
- Optional integrated OCEM computerized interface, based on EIA-709.1 Lonworks Echelon standard protocol (opt. 93).
- Other available options:
  - ❖ RS232 serial port for diagnostic (opt. 25)
  - ❖ Earth leakage local continuous reading (MΩ, kΩ) and earth fault detection (opt. 31)
  - ❖ Lamp fault detection (opt. 36)
  - ❖ Series circuit cutout (opt. 76)
  - ❖ Nylon wheels (opt. 85)
  - ❖ Finish according to customer requirement (opt. 86)
  - ❖ AENA ANEXO compliance (opt. PPT2/04/04)
  - ❖ J-BUS port (opt. JB)

## Other features

- **Output power:** 2.5 kVA, 4 kVA, 5kVA, 7.5kVA, 10kVA, 15kVA, 20kVA, 25kVA and 30kVA.
- **Single-phase power supply voltage:** 208VAC, 220VAC, 230VAC, 240VAC, 480VAC +10% -5% (FAA). The regulators are designed to work with the input voltage down up to -10% providing IEC performances.
- **Frequency:** 50 or 60 Hz  $\pm$  7.5%.
- **Maximum output current to the series circuit:** 6.6A, adjustable through step from 1.8A. The output current values are accurately regulated within the limits stated by the Specs, considering the following operating conditions which can be happened contemporary too:
  - \* any load from short circuit to full rated load
  - \* any input voltage within -5% (-10% for IEC) + 10 % of the rated input voltage, at the rated frequency;
  - \* any of the hereabove described environmental conditions
  - \* maximum 30% of the secondary windings of the isolating transformers open-circuited, considering a rated load not less than 50% of the rated one.
- **Efficiency :** not less than 0.90, with rated input voltage, at the maximum output setting (6.6A), with rated resistive load. Average efficiency exceeding IEC requirements.
- **Power factor :** not less than 0.97, with rated input voltage, at the maximum output setting (6.6A), with rated resistive load. Power factor exceeding IEC requirements.
- **Total Harmonic Distortion:** THD of input current: <5% with resistive load between 100% and 10% of the nominal, at rated input voltage and maximum output setting (with sinusoidal input voltage and PWM controlled power transistors module).
- **Remote control voltage:** 24 VDC, 48 VDC, 60 VDC or 120 VAC, internal or external.
- **Protection degree:** IP 20.

## EQUIPMENT DESCRIPTION

The unit is assembled into a metal box consisting of a structural frame, a front panel, a rear panel, both of them screwed to the frame, and one front crate mounting all the CCR control/monitoring withdrawable PCBs.

The front and rear panels can be removed, by unscrewing the relevant fixing screws, for complete inspection of the inside components.

The CCR is equipped with a main circuit breaker, rated according to the its power, to protect the power supply line and to surely cut out the power supply to the regulator .

The PCBs support keyboards, displays and signalling leds.

The finishing is made by phosphating and baked electrostatic epoxy powder coating, colour RAL 7032.

The assembly is equipped with four lifting eyebolts. The lower side of the unit is suitably shaped, to allow the handling by means of a fork truck too.

The cable entrance is provided through the bottom of the unit.

One grounding bolt, complete with washers and nuts, is outside provided in the right rear side of the unit (close to the bottom). Inside the unit (always in the rear side, close to the bottom) a grounding bar allows the grounding of all the unit metallic parts through screws, washers and nuts.

The identification label, including electrical and manufacturing data and standard conformity, are mounted on the front side of the regulator.

Warning labels are placed outside and inside the unit.

**Dimensions** (CCRs up to 15 kVA): 475 mm wide, 750 mm deep, 1530 mm high. (CCRs 20 ÷ 30 kVA): 600 mm wide, 900 mm deep, 1630 mm high.

## THEORY OF OPERATION

(1) Input circuit: consists of an input filter for EMC compatibility, a two-pole circuit breaker and a single-pole load contactor.

(2) Power supply filter: consists of a two-phase inductance and capacitor(s)

and filters the harmonics generated by the power module.

(3) Normally operating PWM (Pulse Wave Modulation) power module: consists of a suitable circuitry topology, including power diodes and IGBT with measuring sensors, provided with PWM control. The width of the pulse is modulated to follow the theoretical 50 Hz sinewave, as fixed by the control system (set point). The frequency of the carrier pulse is 7.5 kHz and the modulating sinewave has a line frequency.

(4) Stand-by power module: consists of two power thyristors, mounted in antiparallel, which are triggered according to the reference control signal (set point). This module is automatically inserted in case of main power module failure or in case of failure of the fans, provided for its forced ventilation. This block is not present on UR2000 regulators.

(5) Output filter: consists of an inductance, which filters the 7.5 kHz frequency of the carrier and practically allows the passage of the fundamental harmonic only.

(6) Power transformer: increases the output voltage and isolates the constant current regulator from the series circuit.

(7) Control and diagnostic circuit: this circuit, based on DSP technology, constantly monitors the input voltage and current, the output current of the power module, the load voltage and current, to grant the correct operation of the unit. The internal loop assures the maximum bandwidth to provide a very fast response to any instantaneous changes at the CCR output (from full load to short circuit conditions).

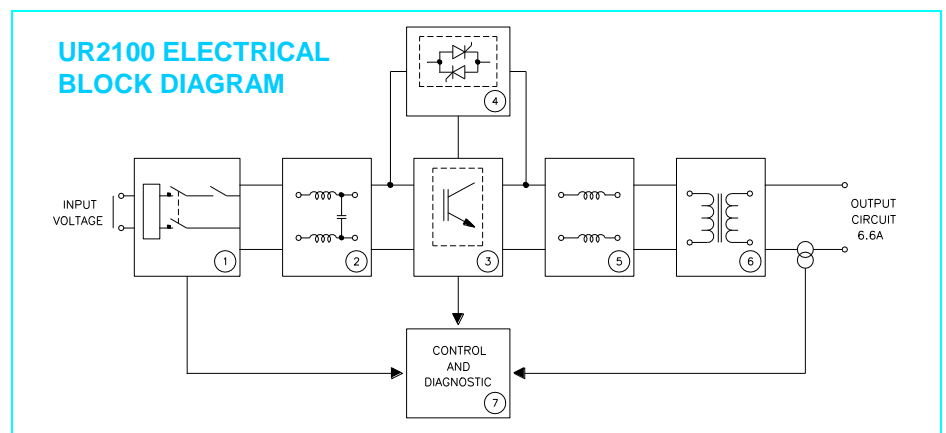

**EnergyTechnology**

Via della Solidarietà, 2/1  
40056 Valsamoggia Loc. Crespellano – Bologna (Italy)  
tel: +39 051 6656611 - fax: +39 051 6650099  
e-mail: ocem@ocem.com - web: www.ocem.com