



# LITC

## LED INSET TAXIWAY CENTRELINE, STOP BAR AND INTERMEDIATE HOLDING POSITION LIGHT



### COMPLIANCES

**ICAO:** Annex 14 - Volume I Fig. A2-12-13-14-15-16  
**FAA:** L-852A-B-C-D-J-K(L) AC150/5345-46 and EB No.67  
**IEC:** TS 61827  
**NATO:** STANAG 3316  
**CAA:** CAP 168  
**IAAE:** TP312

### APPLICATIONS

Taxiway centreline, stopbar and intermediate holding positions for ICAO CAT I,II and III, FAA and military taxiway

### BENEFITS

- 60000 hours LED rated life at full intensity, but over 100000 hours in field operating conditions
- In new installation, LED lights mean lower loads, lower size of CCRs and transformers, thus low life cycle costs
- The light output is variable like a traditional halogen lamp, as indicated by the FAA "Engineering Briefing No.67"
- Colour emitted directly by LEDs: absence of coloured filters ensures no energy losses and no colour shifts
- Fully compatible with existing AFL infrastructure\*
- Designed with simplicity allowing longer maintenance intervals and fewer spare parts
- No use of sealant to fix the prisms in the dome thanks to customized gaskets, making their replacement quick and easy
- No optical adjustment after LED module or prism replacement
- Valve for watertightness test after overhaul
- Operating with any topology of CCRs designed in compliance with IEC or FAA requirements

\* For monitored fixtures, isolation transformer max size: 200VA

### PERFORMANCES

- The electronic is strong-built and highly resistant to shock and vibration
- Automatic adaptation to the frequency of the supply current
- A surge protection device is provided in the electronics as required by the FAA "Engineering Briefing No.67"
- Immediate detection of an internal fault
- 6.35 mm protrusion strongly reduces vibrations to aircrafts and to light itself, increasing its lifetime
- Dome smooth outer profile makes the light less sensitive to snowplough blades
- Bidirectional or unidirectional, 8" or 12" dia.
- Drop-forged dome and cast aluminium lower cover make the fitting sturdy, but lightweight too for ease handling in the field
- Light output practically not affected by heavy rainfall thanks to the shallow channel in front of the prism windows
- O-Ring placed outside the dome to avoid dirt deposits between light and base
- Protection degree: IP67
- Temperature range: -55°C to +55°C

### INSTALLATION

- Suitable for 8" or 12" dia. bases
- Adaptor ring for 8" light installation on 12" dia. bases
- Specific tools available for easy and precise installation

**PHOTOMETRIC PERFORMANCES**

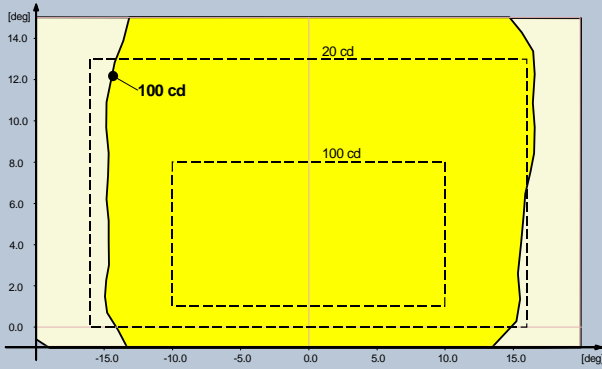

Fig. 1 ICAO A2-12 Straight Section – Yellow

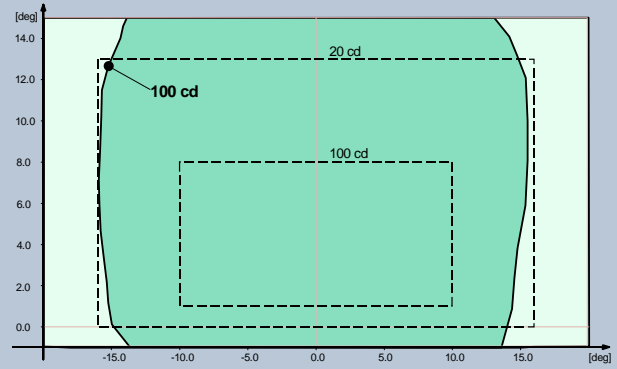

Fig. 2 ICAO A2-12 Straight Section – Green

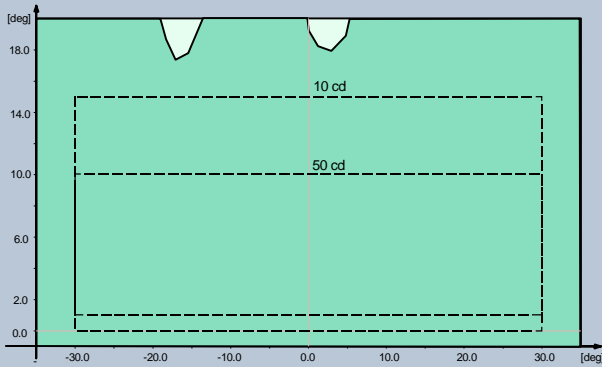

Fig. 3 FAA L-852D – Green

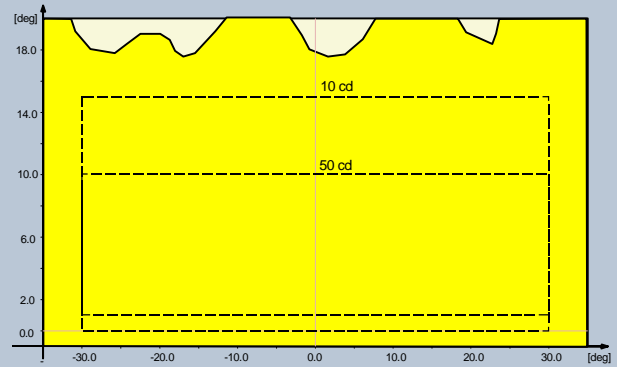

Fig. 4 FAA L-852D – Yellow

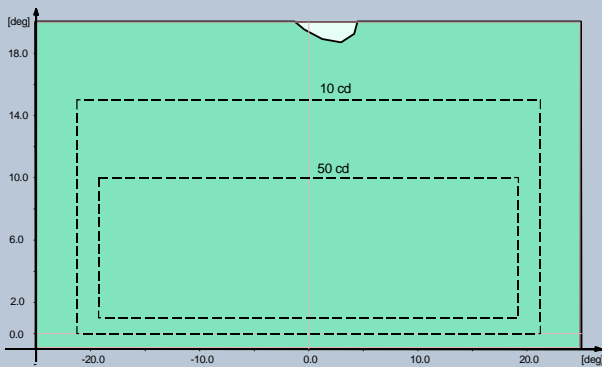

Fig. 5 FAA L-852K – Green

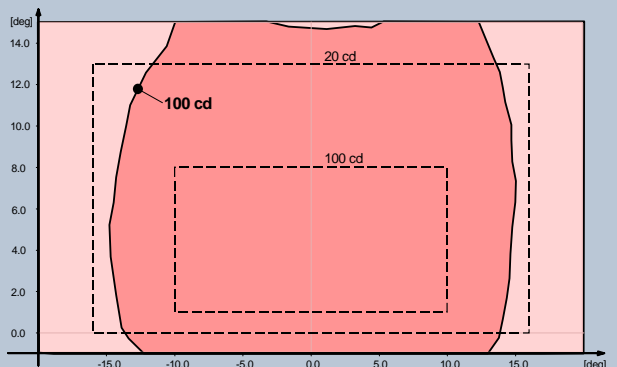

Fig. 6 ICAO A2-12 Straight Section – Red

**TABLES**

**POWER CONSUMPTION\***

Electrical System	1 Plug	2 Plugs
Unidirectional 8"-12" (w/o Arctic Kit)	7 VA	-
Unidirectional 8" (with Arctic Kit)	27 VA	-
Unidirectional 12" (with Arctic Kit)	47 VA	-
Bidirectional 8"-12" (w/o Arctic Kit)	12 VA	14 VA
Bidirectional 8" (with Arctic Kit)	32 VA	54 VA
Bidirectional 12" (with Arctic Kit)	52 VA	94 VA

\* Measured at 6.6 A and referred to the highest consumption configuration

**POWER FACTOR**

Input Step	2.8 A	6.6 A
Power Factor	0.96	0.98

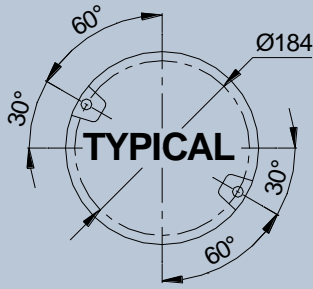

Light Fixture 8" dia.

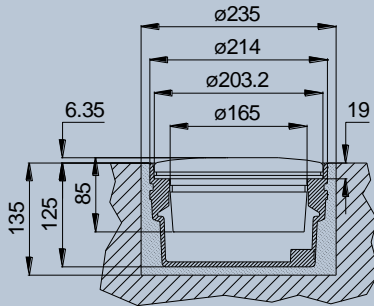

Shallow Base 8" dia.

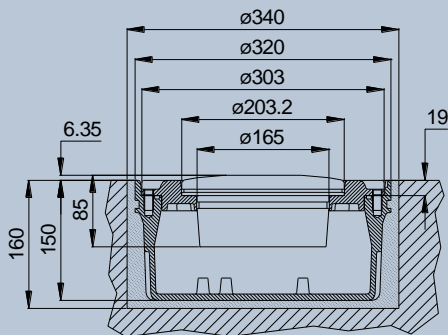

Shallow Base 12" dia.

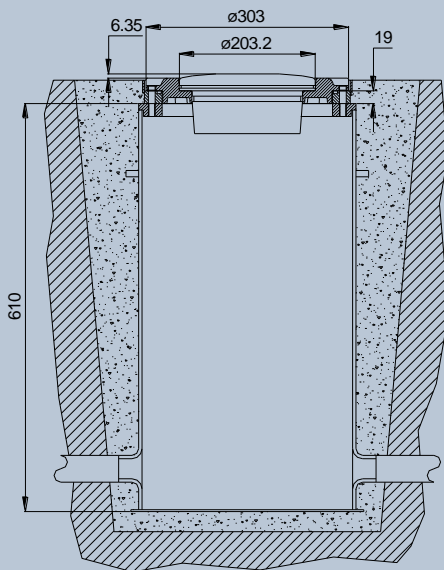

L-868 Deep Base 12" dia.

**LITC08 - F - D - GG - 2P - 0 - M - A**

**Basic P/N:**

08 = 8" Fixture  
12 = 12" Fixture

**Compliance:**

I = ICAO CAT III  
S = ICAO CAT I-II  
F = FAA

**Use Code:**

(Refer to TABLE A)

**Colour (Side A)/(Side B)\*:**

G = Green  
Y = Yellow  
R = Red (not for FAA)  
M = Blank (unidirectional dome)\*\*

**Electrical System:**

1P = One Plug  
2P = Two Plugs

**Mounting Assembly:**

0 = No mounting Assembly  
R = Adaptor Ring 8"-12" dia.

**Monitoring:**

0 = Without Monitoring  
M = With Monitoring

**Arctic Kit:**

0 = Without Arctic Kit  
A = With Arctic Kit

TABLE A

USE	I = ICAO CAT III	S = ICAO CAT I-II	F = FAA
A	Fig. A2.12 straight before and after curves	Fig. A2.15 straight	L-852A
B			L-852B
C	Fig. A2.13 straight		L-852C
D			L-852D
W	Fig. A2.14 curved	Fig. A2.16 curved	
K			L-852K
J			L-852J

\* For curved sections it's necessary to specify the colour of each side, "A" and "B", due to the fixture toe-in

\*\* The aperture not finished "M", on straight sections fixtures, will be always on side "B"

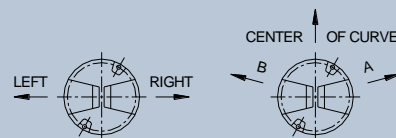

Straight and Curved Section Orientation

**RENEWAL PARTS FOR LIGHT UNIT**

- 1 Dome
- 2 O-Ring for dome
- 3 O-Ring for lower cover
- 4 Prism Gasket
- 5 Prism
- 6 Prism holder gasket
- 7 Mounting plate
- 8 Lower cover with electronic, plug and valve
- 9 Valve for watertightness test
- 10 Arctic Kit heater
- 11 Arctic Kit thermostat
- 12 LED module with accessories
- 13 Reflector with hardware
- 14 Lower cover gasket
- 15 FAA L-823 plug

Refer to the relevant technical manual for the complete list of the available spare parts

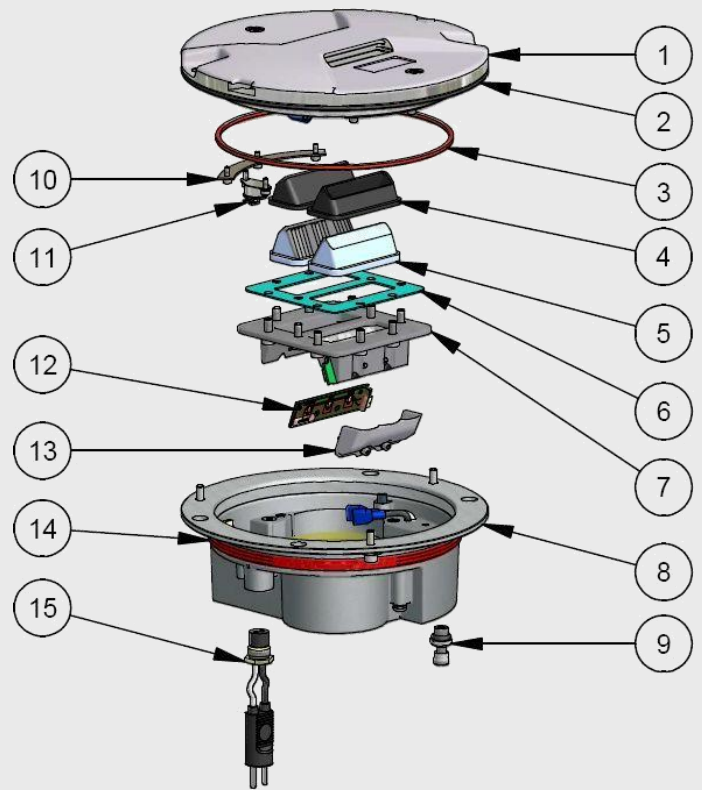
**ACCESSORIES**

- 315.1230 Base L-868 type, class IA, size B, 24" deep \*
- 315.1420 Flange ring with pavement dam for L-868 base, size B, with O-Ring and bolts
- 152.5251 Shallow base, 8" dia., one cable lead, with hardware
- 152.5261 Shallow base, 8" dia., two cable leads, with hardware
- 152.8110 Shallow base, 12" dia., one cable lead, with gasket and hardware
- 153.1110 Shallow base, 12" dia., two cable leads, with gasket and hardware
- 152.6116 Adaptor Ring 8"-12" dia. complete with hardware
- 712.1034 Setting material for shallow base, 10 lt
- 712.1035 Quartz for shallow base, 25 kg
- 332.4301 Positioning jig for 8"-12" dia. shallow base, without optical device
- 332.4351 Optical device for positioning jig to allow a very precise light unit orientation
- 332.4330 Watertight/shockproof plastic case complete with positioning jig for base and optical device
- 332.4140 Lifting tool (2 pieces to work properly)

\* Sectional bases may be required depending upon the paving technique

For any information about isolating transformers and connectors, please see the specific catalogue pages

**8" Shipping Weights and Volumes**

	Light Unit	Shallow Base	Light Unit & Adaptor Ring
<b>Weight (kg)</b>	3.6	3.2	6.75
<b>Volume (m<sup>3</sup>)</b>	0.007	0.007	0.013

**12" Shipping Weights and Volumes**

	Light Unit	Shallow Base
<b>Weight (kg)</b>	5.9	7.3
<b>Volume (m<sup>3</sup>)</b>	0.022	0.022

We reserve the right to change the design or specification data without notice

UC-PU-0260\_EN-Rev.C