



# LERE

## LED ELEVATED RUNWAY EDGE AND THRESHOLD/END LIGHT



### COMPLIANCES

**ICAO:** Annex 14 - Volume I Fig. A2-3, A2-8, A2-9, A2-10  
**FAA:** L-862-E(L) AC150/5345-46 and EB No.67  
**IEC:** TS 61827  
**NATO:** STANAG 3316  
**CAA:** CAP 168  
**IAAE:** TP312

### APPLICATIONS

Runway edge and threshold/end for ICAO CAT I,II and III, FAA and military runways

### BENEFITS

- 60000 hours LED rated life at full intensity, but over 100000 hours in field operating conditions
- In new installation, LED lights mean lower loads, lower size of CCRs and transformers, thus low life cycle costs
- The light output is variable like a traditional halogen lamp, as indicated by the FAA "Engineering Briefing No.67"
- Colour emitted directly by LEDs: absence of coloured filters ensures no energy losses and no colour shifts
- Fully compatible with existing AFL infrastructure\*
- Designed with simplicity allowing longer maintenance intervals and fewer spare parts
- Customized gasket for glass cover to avoid the use of sealing
- No optical adjustment after LED module or lens array replacement
- Operating with any topology of CCRs designed in compliance with IEC or FAA requirements

\* For monitored fixtures, isolation transformer max size: 150VA

### PERFORMANCES

- The electronic is strong-built and highly resistant to shock and vibration
- Automatic adaptation to the frequency of the supply current
- A surge protection device is provided in the electronics as required by the FAA "Engineering Briefing No.67"
- Immediate detection of an internal fault
- Lightweight and sturdy due to aluminium die-castings
- Powder coating surface finishing to provide good corrosion resistance
- Body balanced on the slipfitter for proper levelling by means of four external screws
- High jet blast resistance due to the small size of the fixture, 320 mm high
- Protection degree: IP67
- Temperature range: -55°C to +55°C

### INSTALLATION

- The fixture can be installed on pipe elbow or baseplate
- Specific tools available for easy and precise installation

**PHOTOMETRIC PERFORMANCES**

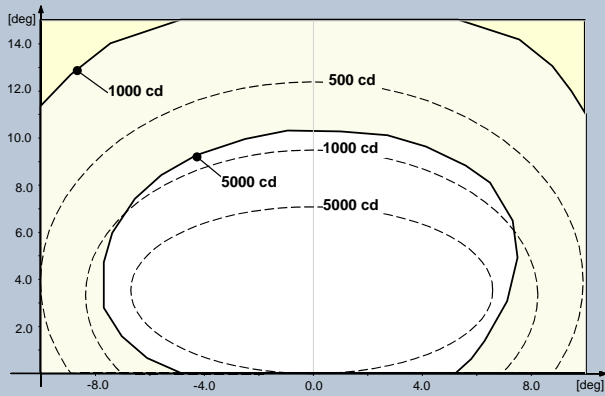

Fig. 1 ICAO Fig. A2-10 60 m – White

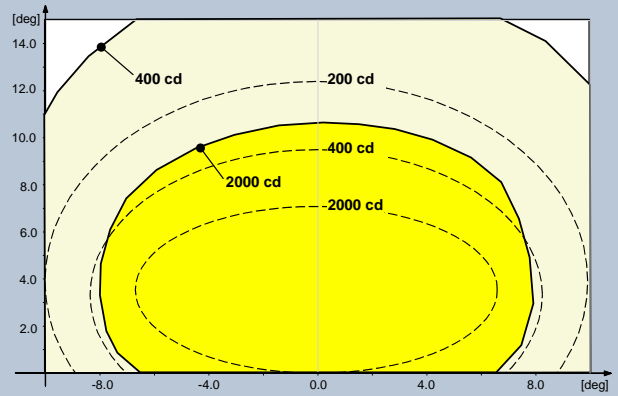

Fig. 2 ICAO Fig. A2-10 60 m – Yellow

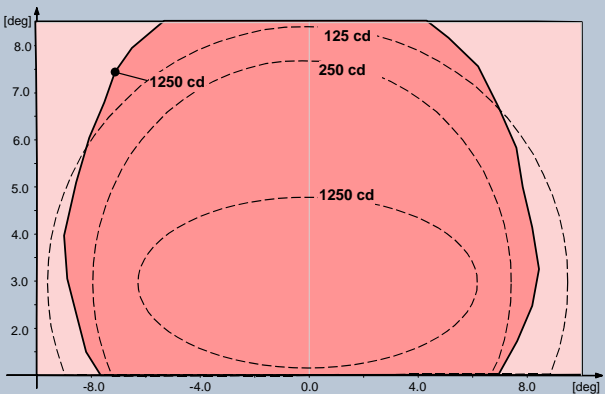

Fig. 3 ICAO Fig. A2-8 – Red

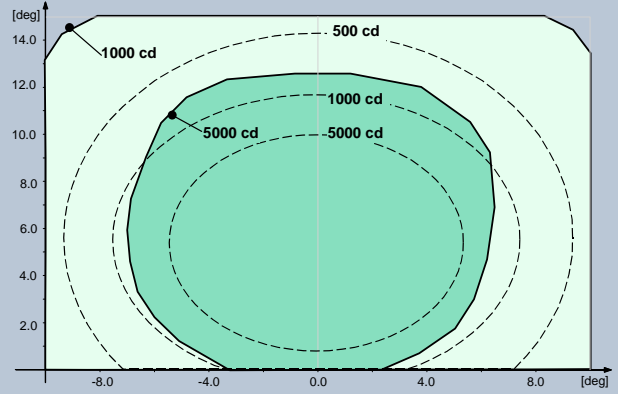

Fig. 4 ICAO Fig. A2-3 – Green

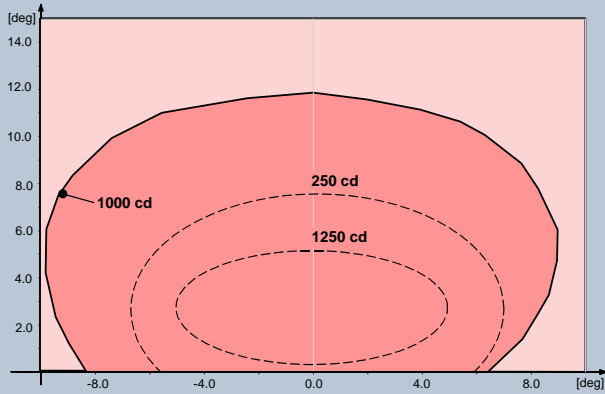

Fig. 5 FAA L-862E – Red

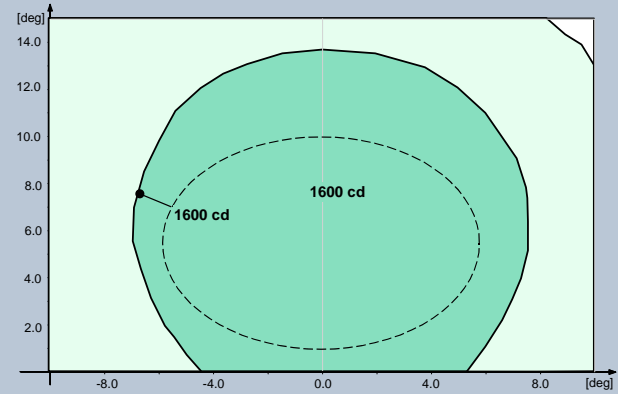

Fig. 6 FAA L-862E – Green

**TABLES**

**POWER CONSUMPTION\***

<b>Electrical System</b>	<b>1 Plug</b>
<b>Bidirectional (w/o Arctic Kit)</b>	<b>40VA</b>
* Measured at 6.6 A and referred to the highest consumption configuration	

**POWER FACTOR**

<b>Input Step</b>	<b>2.8 A</b>	<b>6.6 A</b>
<b>Power Factor</b>	<b>0.96</b>	<b>0.98</b>

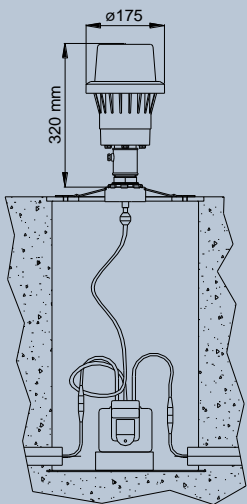
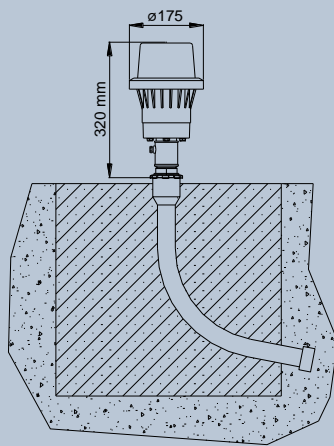
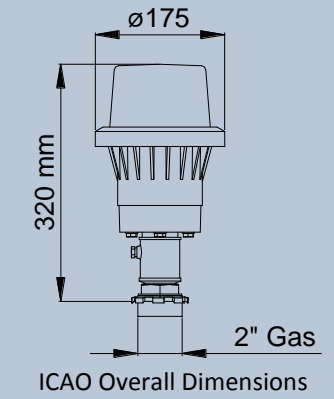

**LERE - F - T - WR - 14 - C - M - 0**

**Basic P/N:** \_\_\_\_\_

**Compliance:** \_\_\_\_\_

- S = ICAO 45 m Runway Edge and Threshold/Runway End
- I = ICAO 60 m Runway Edge
- F = FAA

**Use:** \_\_\_\_\_

- T = Threshold/End
- E = Edge

**Colour(Side L)/(Side R)\*:** \_\_\_\_\_

- W = White
- Y = Yellow
- R = Red
- G = Green
- M = No LED Source (unidirectional light)

**Height:** \_\_\_\_\_

- 00 = Without pole (only "I" and "S" Compliance)
- 14 = 14"
- 20 = 20"
- 24 = 24"
- 30 = 30"

**Breakable Coupling:** \_\_\_\_\_

- A = 1"1/2-12 UNF
- B = 2"-11 1/2 NPS
- C = 2"-11 GAS (mandatory for "00" Height)

**Monitoring:** \_\_\_\_\_

- 0 = Without Monitoring
- M = With Monitoring

**Arctic Kit:** \_\_\_\_\_

- 0 = Without Arctic Kit

\*The beams aiming is not field adjustable

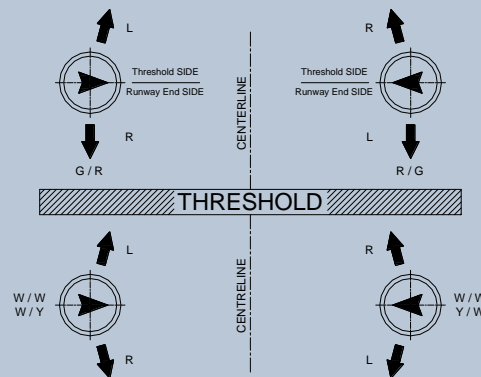

**RENEWAL PARTS FOR LIGHT UNIT**

- 1 Clear outer glass cover
- 2 Gasket for glass cover
- 3 LED module
- 4 Lens array
- 5 Glass cover locking ring
- 6 Body with electronic and plug
- 7 Breakable coupling with
- 8 Ring nut
- 9 FAA L-823 plug

Refer to the relevant technical manual for the complete list of the available spare parts

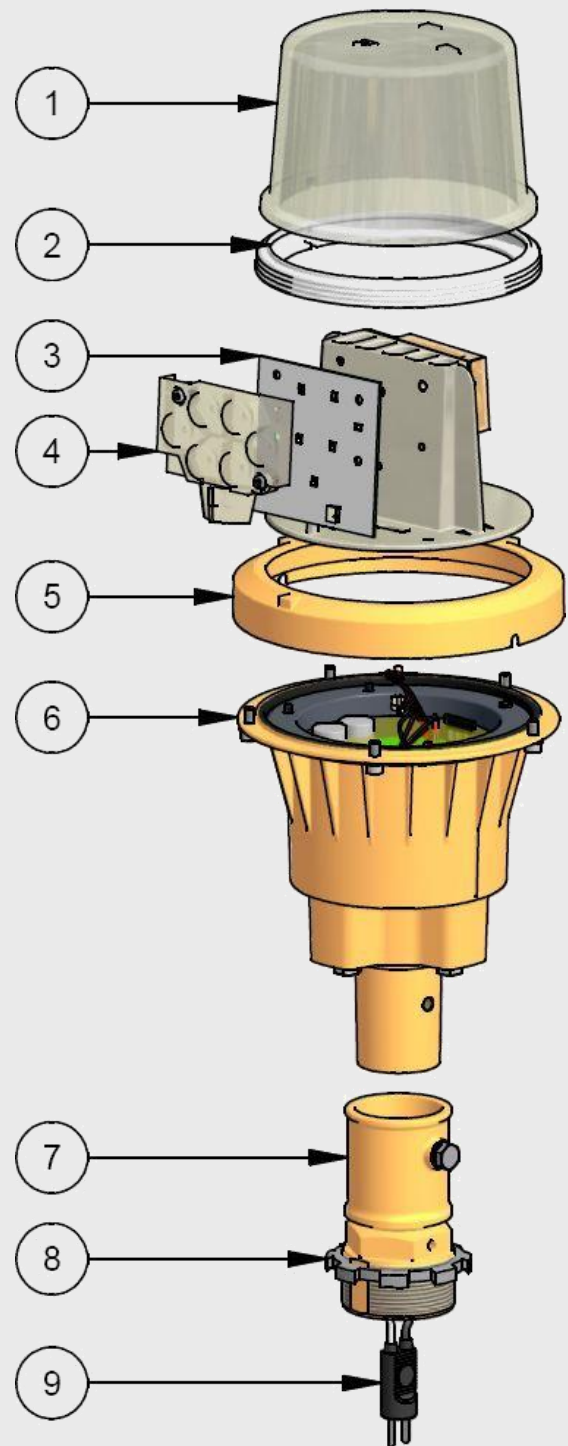
**ACCESSORIES**

- |          |   |
|----------|---|
| 013.0008 | Galvanized steel pipe elbow with upper threaded end only (2" - 11 GAS thread) |
| 315.3210 | Galvanized steel pipe elbow with both threaded ends (2" - 11 GAS thread)      |
| 013.0010 | Set of two ryton rings for receptacle support inside pipe elbow               |
| 315.1228 | Base L-867, Class IA, Size B, 24" Deep  |
| 315.1062 | Baseplate for L-867 base with gasket and cable clamp (2"-11 GAS thread)       |
| 315.1063 | Baseplate for L-867 base with gasket and cable clamp (2" - 11 1/2 NPS thread) |
| 315.1082 | Baseplate for L-867 base with gasket and cable clamp (1"1/2 - 12 UNF thread)  |
| 332.4556 | Levelling device  |

For any information about isolating transformers and connectors, please see the specific catalogue pages

**Shipping Weights and Volumes**

	Light Unit
Weight (kg)	5.0
Volume (m <sup>3</sup> )	0.016

We reserve the right to change the design or specification data without notice

UC-PU-0264\_EN-Rev.B